

Planets Zodiac and The Chemical Elements

Throughout this text there has been reference and diagrams, outlining the double planetary rulers of the elements. Along with this reference comes a question of what zodiacal relationships could be made to the Periodic Table. Seeing as though it is now a circle it is reasonable to assume there would be a correspondent reference for the Zodiac.

My approach to this question extends from a similar question, that had to be asked of Dr Lievegoed's work on the plant processes relationship, to planetary influence. While he gave a wonderful image of this relationship he made no mention of the Zodiac. While he gave images of the two sided planetary activity, and gave similar images of the biodynamic preparations relating to these processes, he did not give any indication for how we were to specialise the preparations to take advantage of either of these individual activities. It seemed that if the zodiac relationships could be established, then refining the tasks of making, and application of the preparations, could be carried out during periods when these constellations were activated. Particularly when the ruling planet was within its ruling constellation, or say the Sun or Moon's transits of these constellations.

Lievegoed's book is a difficult read, mostly due to it being the text of a talk he gave, and thus it is quite minimal in its size, but also it takes certain liberties with the basic knowledge of the reader. Thus some of the images and concepts seem a bit foreign at first. I read it probably 20 times before I really started to feel I had an inkling of what he was saying. Sometime in the early 2000s, Dave Robison from Oregon edited the original text, into a more acceptable form of English, which helps tremendously in a basic comprehension of these ideas. So when I came to look at finding the zodiac references I used his text as the basis.

There exists another book, within the biodynamic lexicon, called "Nature of Substance" by Dr Hauschka. Here he outlines an image of chemistry based upon the 12 'dominant' elements, found within the three great spheres of our environment. In the atmosphere we find Hydrogen, Nitrogen, Oxygen and Carbon. In the oceans we find Sodium, Magnesium Chlorine and Sulphur, while in the Earth /Geosphere we find Calcium, Silica, Aluminium and Phosphorus. He gives wonderful images of how these work together in their spheres to anchor various activities, which in each case he relates to a constellation. Sadly he uses the seasonal references of the northern hemisphere to support his argument. Being a southern hemisphere resident, naturally these references are not compatible with my experience of these constellations, and

initially I did have 'a reaction' to his relationships. Nevertheless, as a Steiner chemist he is using the same reference system as Lievegoed for most of his images, so it is possible to play them off each other to see where similarities could be established. To add to this, I have my own 45 years of experience of the zodiac to add to the mix. To make things easier still is the fact that the choice of which zodiac fitted with which planet, was really only a choose between two possibilities. So if something really fitted with one reference then it stood that the other relationship must be so, whether it appeared to fit or not. So overall while it took sometime, it was a 'doable' task. Eventually I published my suggestions as part of 'Energetic Activities' , as I felt it was a natural addition to RS suggestions for the planets within the Agriculture Course. He hinted at the planetary relationships, to the dual Cosmic and Earthly processes, but did not say much more. So Lievegoed's efforts were a tremendous addition, while I hope my efforts have helped this study along somewhat as well. If you are interested in pursuing this topic further , Enzo Nastati has extended this topic, through providing images of how these planetary activities will act, when interacting with the 4 energetic activities. (15)

As a reference to Hauschka with Lievegoed, I can provide the following diagram, while for the whole Periodic Table see the next page. It may be noticed that Hauschka and the Gyroscopic Periodic Table place the planets and zodiac in opposite relationship to the Anions and Cations. They are two different systems. Hauschka uses only 12 elements while the periodic Table has 120. Each system will have its truth within its context.

	Forces			Substances		
Cosmic	O	♊	♃1	♃2	♋	Al
	Cl	♌	♄1	♄2	♍	Mg
	Si	♍	♅1	♅2	♎	C
Earthly	N	♎	♆1	♆2	♏	Ca
	S	♏	♄1	♄2	♐	Na
	P	♐	♃1	♃2	♑	H
	Being			Manifestation		

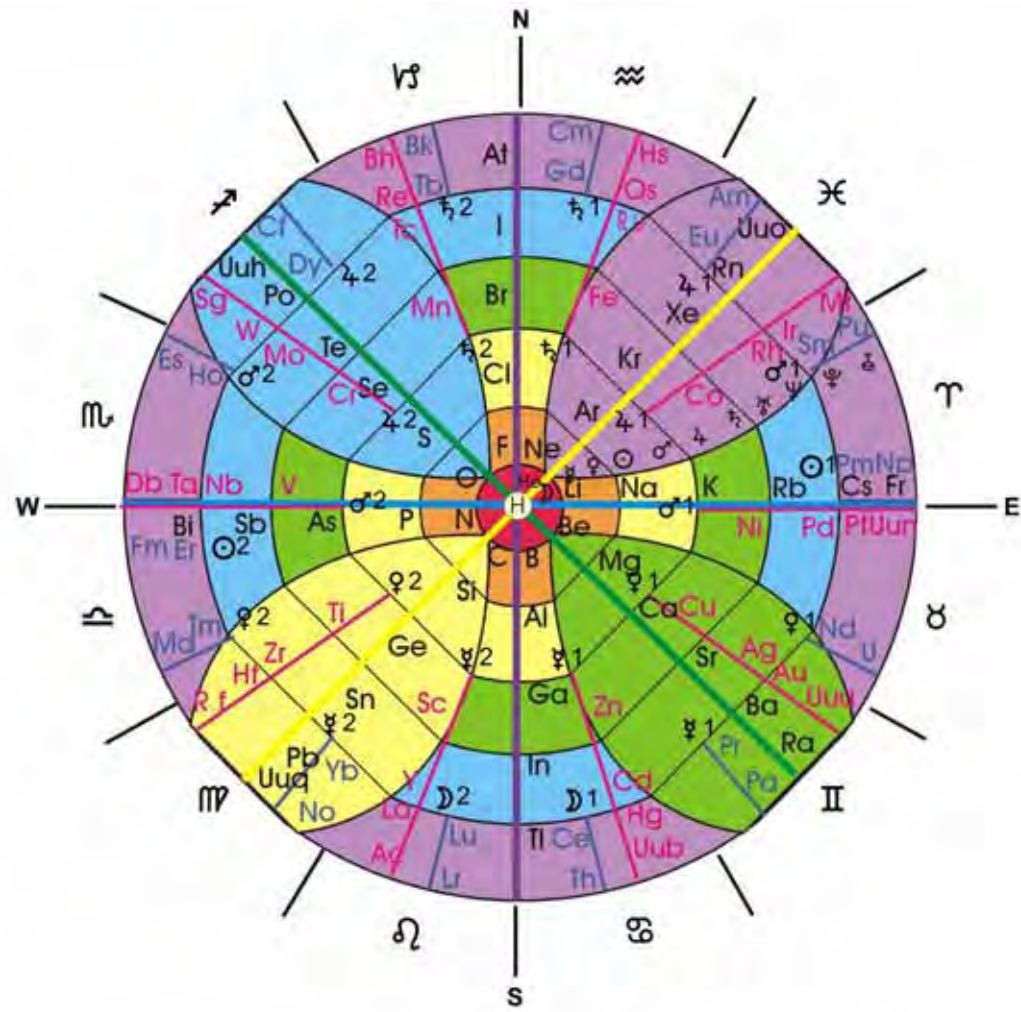

**Glenological Chemistry,
Planets and Signs**
Magnetic North Orientation

3D Gyroscopic Periodic Table

So far I have presented all the diagrams as 2 dimensional images, when in fact they need to be seen as 3 dimensional, given chemical elements are three dimensional spherical beings.

In "The Overview", I presented the two main reference structures of Biodynamics. These being the 'passive rings' gyroscopic diagram of the 'Cosmic' spheres of the Galaxy, Solar System, Atmosphere etc, and the 'moving vortex' gyroscopic diagram, of how the energetic bodies; Spirit, Astral, Etheric and Physical bodies, organise themselves within living organisms. So each of these images have to be moved to 3D images.

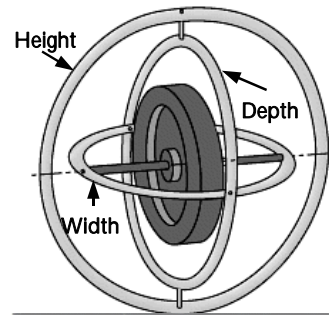

Classically, the gyroscope can be described as having three main axis. Height, width and depth. Two of these, height and depth are on the vertical axis and are at a 90 degree angle to each other, while width is on the horizontal.

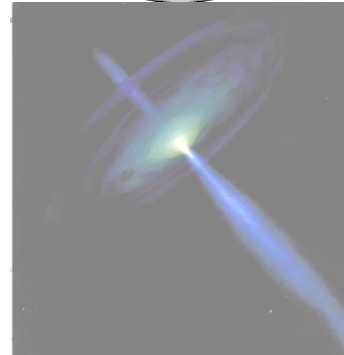

Within the biodynamic model we identify the vertical plane(s), as associated with the Silica and Spirit / Force processes, while we associate the horizontal plane with the Calcium and Earthly / Substance processes.

In Astronomy, we identify the horizontal plane in Galaxies and Solar Systems, as the plane of the matter buildup. This is the flat plane of where the stars and planets are in their respective structures. The vertical axis is often invisible in astronomy, however it is the plane where the vertical vortexes draw forces and matter into the center of the 'organism', before it is squirted out along the horizontal plane.



The third axis , the second vertical axis, is not commonly seen within galaxies or Solar Systems, however recent photographs of 'Gyroscopic Galaxies' provide images of the usual flat plane of the spiral galaxy, with a

perpendicular ring around it.

This is a very interesting form, that will be of special interest when we come to observe the 3D organisation of the Periodic Table. For now though it is enough to observe this as the second vertical axis.

When we draw the 'Cosmic' ring spheres of our environment - the passive spheres - as a 3D picture we obtain the image on the bottom left of this page. Naturally the spheres within this diagram should be circular. I have left the straight lines in these diagrams to provide continuity with the earlier diagrams.

Likewise the same process can be done for the Vortex gyroscope - where the energetic bodies organise themselves once movement is brought into play - we have this second organisation on the bottom right picture.

This 3D organisation of the Vortex gyroscope has brought about an interesting insight, that is not immediately obvious when viewing the 2D diagrams. In the 2D diagram I presented, on page 26, the primary vertical axis of the gyroscope, are where the Physical body and the Spirit were placed. The Etheric and Astral are the opposite poles of the horizontal plane. This follows indications from Dr Steiner given in "The Anthroposophical Approach to Medicine" (1922). In my applications of this 2D diagram, especially when applied to the Periodic Table, it became clear, that when viewing the diagram, the Etheric would be on the left hand side of this diagram and the Astral would be on the right hand side of the diagram. This ordering is due to these diagrams being drawn as if they are orientated to the Sun's path, as seen from a northern hemisphere perspective. This keeps these diagrams consistent with

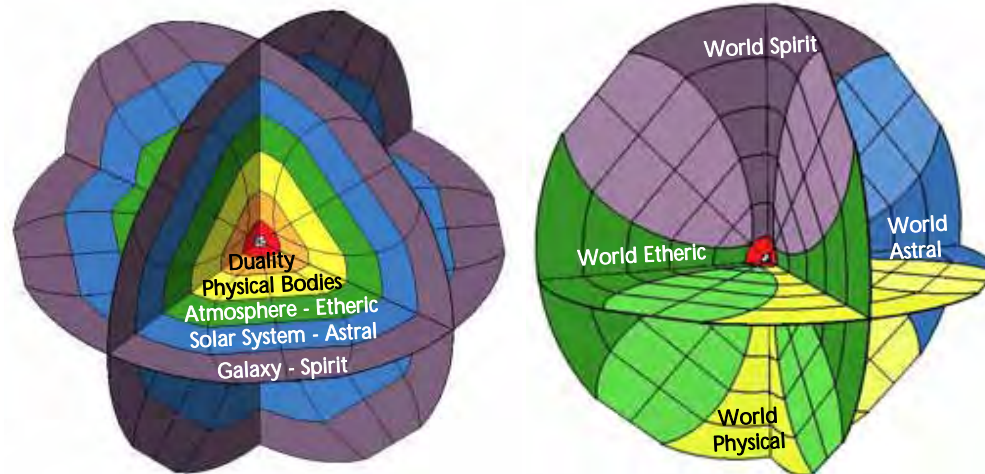

the dominant and common way of orientating birthcharts, as well as many other octagon cultures orientation. See page 115 for a discussion of orientating things from magnetic north, instead of facing south towards the Sun.

When moving to the 3D, I have taken it that each of these three planes, has the basic fourfold organisational pattern at their base. So when these individual planes are put into three dimensions we see the four primary vortexes, are maintained as full vortexes, of their particular body, ie a Spirit vortex, an Astral vortex, a Etheric vortex and a Physical vortex, as is suggested in the 2D diagram. However, something else appears, when the second vertical axis crosses the horizontal axis. Here we have a region where the Physical zone of the horizontal axis (yellow) crosses the Etheric zone (green) of the vertical axis. Likewise, on the other side of the 3D diagram, we have the Astral zone of the vertical intersecting with the Spirit zone of the horizontal axis. This order mirrors a significant reference in life. These bodies work together in these partnerships, externally in nature, as Water and Earth processes moving upwards from the Earth, meeting the Light and Warmth of the Atmosphere. It is at the point of meeting of these four elements at the oceans surface, that Blue Green Algae 'emerged', sparking evolution. Similarly the bodies these elements carry work this way in the various kingdoms of nature, giving us all the manifestation we see.

The 3D Periodic Table

Within the process of 'observing' the Periodic table, there are three groupings of elements, which each vibrate at a different frequency. This suggests they each inhabit different harmonic range of space. These three dimensions are, the 8 Major element Arms that work on the fourth harmonic, the 10 Trace elements that work on the fifth harmonic, and the 14 Actinides and Lanthanides which work upon the seventh harmonic. Each of these have some specific characteristics. In my earlier diagrams I placed them on top of each other to identify their interrelationships, however they should be seen as individual activities, within the greater whole.

The 'Major' 4th harmonic elements form the basis of manifestation. They are the base elements that provided the structures of many forms and activities. They are found at every ring of the Periodic Table. Generally, the elements in the inner rings are those that most actively support life, while the further out in the spheres one goes, the more toxic the elements become. Very few of the major elements found to support life are placed beyond the fourth or Etheric (green) sphere of the Periodic table.

The major elements begin with Hydrogen, which is placed at the very center,

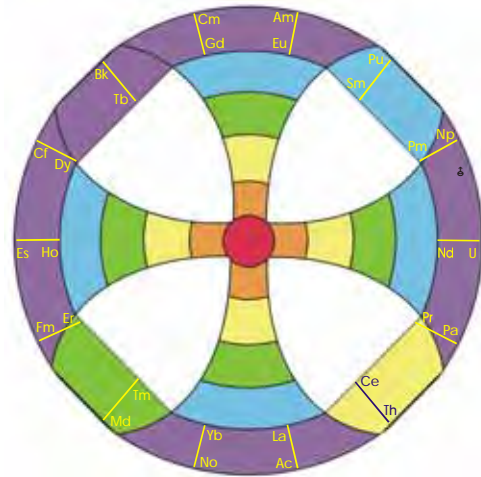

Within the biodynamic reference of plant growth we are presented with two Silica processes. One coming from the Earth, up through the inside the plant moving upwards, called the Cosmic Silica / Cosmic Forces process, and another coming from the environment in the light and the warmth called the Terrestrial Silica / Cosmic Matter. This external light and warmth process strongly influences the skin formation of the fruit, while the internal silica process is found in the formation of the seed within the fruit. This outer Galactic ring of the gyroscope is the 'skin', boundary setting influence, of the Cosmic Spirit sphere.



Given that this outer sphere is a spiritual sphere, we would expect to place these 7th harmonic elements, on a vertical axis.

The next step is to put these three planes together. The picture on the next page is the result.

Two Orientations

On page 13, we found there were the two orientations of the gyroscope. The axis based upon Magnetic North and the axis based upon the Zenith. While this difference may not seem of particular significance for dwellers of the southern hemisphere, as both are in basically the same direction and we naturally orientate to 'the north', it is a significantly different thing for the people of the northern hemisphere. They naturally orientate to the Sun, and thus to the Zenith axis, which means facing 'everything' to the South. So to orientate anything off magnetic north means they must turn in the opposite direction.

My world view has developed from my studies of Astrology, which in turn is developed from the long cultural tradition of orientation to the Sun and its path of movement in front of the Zodiac, from a northern hemisphere perspective. Rightly so, I might hear you say, however with this acceptance comes a particular orientation towards the world, that has its own peculiar difficulties.

When I began developing circular images from my 'biodynamic' vortex diagrams, (which is only one small part of the spherical gyroscope), I was naturally drawn to the frame of reference presented in the Astrological birth chart. There is several millennia of reference material developed around Astrology, so there is plenty of information to draw upon, to find the inner nature of the circle, and then to some degree also the gyroscope.

The birth chart commonly used today is however a very specific beast. I have written about its peculiarities at http://old.garudabd.org/books/4_6.html and in 'BD questions Astrological Answers'. There I emphasised how it is somewhat removed from the astronomical reality. The specific issues that concern us here is that the 'birth chart' is a map of where the planets are placed at the moment of birth, in relationship to the background of the Zodiac, as seen from the Earth.

When looking at the birth chart for indications of the activity of various 'spaces', it is useful to look to where the eastern horizon is at birth. This is determined from the birth time at a specific place. This allows us to mark off the 'houses'. These areas begin at the eastern horizon, and are marked off in an anti clockwise direction. As they are based upon the Earth related eastern horizon, the houses indicate the various physical areas of our life, that any particular planetary energy will emphasis, e.g. personal finances, home, work, societal interaction etc.

By marking off the path of the planets and the Sun, along the ecliptic, we observe the path the planets take through the night, at the 'bottom' of the

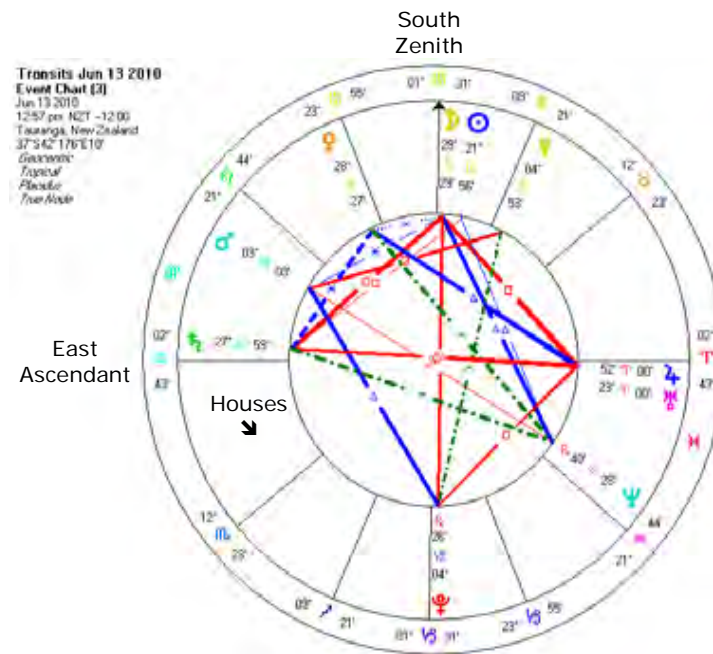

chart , and where they travel through the day time being the 'top' of the chart. Where the Sun reaches the highest point on the sky during the day , we call this point the Zenith. With this being the 'highest' point of the Sun's travel, we associate this with the area where we impact the most upon the world, Symbolically, this means that the Sun , which is the macrocosmic representative of our internalized spirit, is reaching it highest expression. Thus this is the place of an individual's direction, purpose and influence, which is often ones career. It can also show as the husband's / partners career.

Given that we have marked off the Eastern horizon, we have also marked the western horizon. From this we gain the image that the Sun's zenith, would be a 'northish' point, while the night time point would be a 'southish' point. This is particularly easy to make this association when living in the Southern hemisphere as we look to the north whenever we look to the ecliptic.

However it is all somewhat more complicated than this. Astrology has developed over its 5000 year history in the northern hemisphere. In the northern hemisphere, the ecliptic, or the Sun's path, crosses in the southern part of the sky. Thus to read a birth chart, or work with any zodiac orientated perspective, generated in the universally accepted north hemisphere orientation, we must first face to the south. Then we have the eastern horizon (Ascendant) on our left and the western horizon (Descendant) on the right hand side. So this 'northish' point is

actually pointing to the south.

So to read this chart correctly you must first face to the South pole.

Birth charts are two dimensional diagrams drawn on paper. Therefore we do not fully experience the three dimensional reality of the gyroscopic solar system. We do not see the different distances the planets are from the Sun, nor do we see the different inclinations from the ecliptic that each planet has. So we do not have to really confront the reality of what the birth chart is. In fact, we take a tremendous amount for granted, when we accept the western birth chart, as the 'normal' point of reference. I am not saying it is wrong, just that it is a very specific document that gives us very specific information.

So how does the birth chart relate to the gyroscopic sphere?

Within a gyroscopic sphere we have three planes, we have the circle of height, the circle of depth, and the circle of width. Thus we have two vertical planes and one horizontal plane. The vertical planes are orientated off the magnetic north point, which we call North. Therefore we have South opposite. If we stall the gyroscopes spinning movement for a moment, we can also identify a East point and a West point at ninety degrees to the vertical axis. The third plane is across the horizontal plane. So while this horizontal plane can have a east and west point, it can never face North or South, as it is always 90 degree to the axis that defines North.

This reality becomes significant when we realise that our planets are all manifestations of the horizontal plane of the Sun's gyroscopic nature.

Gyroscopic physics states that as the 'Sun' gyroscope spins, it sucks in matter and forces in its north and south poles, and then squirts matter out along its equator. The Sun's magnetic fields then organise this substance into rings, which over time have organised themselves into gyroscopic balls, we call planets. These in turn suck in cosmic dust and any other Sun 'garbage' through their north and south poles, consolidating this into its planetary substance. Thus we have the planets, lined out along the horizontal plane.

In a perfect solar system, all of the planets would move along one horizon line, however they do not. Mostly though they do move within 5 degrees either side of the horizontal. One significant thing we need to consider is the Earth being 23 degrees tilted off its true North South axis. So in our daily orbit, we see the Sun's plane move higher and lower in the sky, while to a greater extent throughout the year, this angle provides us with our seasons.

This brings us to the Zodiac. The Zodiac is that band of stars, in front of which the Sun and the planets moves. It is the band of stars wrapped around the horizontal

plane of the Sun's or the Earth, gyroscope, depending on which orientation— Heliocentric or Geocentric - you choose to use.

So while we identify the Sun's midday point as the highest part of the Sun' path, and identify its 'northish' qualities, it is not really true. Firstly in the Northern hemisphere you will be looking South, and even in the Southern hemisphere, the north pole is still 90 degrees away from the point, we are looking at when we see the Zenith.

A secondary problem arises for the northern hemisphere as. When we look south to see the Sun, this places the east on the left, and west on the right hand. From this orientation, we then develop a reference system based largely upon the astronomical and natural observations. We extrapolate that the daytime (above) of the chart indicates an extrovert personality, when a predominate number of planets are placed there. While the night time area, with planetary predominance, suggests a introverted orientation. We then follow onto the quadrants of the circle, being divided into collective (left) and personal (right) areas of life, which leads us to all the house definitions, and so on. This is all very well and many fine things have been developed from this reference, over the last few thousand years. The key thought though is, this orientation is towards the Sun's horizontal plane.

This is all very well, however there is another very worthwhile orientation to consider when living as a being upon planet Earth, and this is to reference ourselves off True Magnetic North.

As electro magnetic beings, we have a natural north south polarisation within our magnetic field — head to the north, feet to the south — and some say that being aligned to the Earth's magnetic field, especially during sleep, is a beneficial experience, which helps to realign the static electricity within our bodies, back into a naturally harmonic resonance.

When we look into the Earth sculptures of ancient cultures, foremost of which would have to be the gothic cathedrals, we find they are aligned through the North / South, East / West axis, with an emphasis of their main hall often, along the East West axis. More ancient cultures, like the American Indians, with their medicine wheel, the Buddhists mandalas and the Mayan Calendar also orientate themselves off the Earth's North South axis. This makes very good sense, as we are primarily Earth beings and therefore why not orientate off our environment. However there is still some confusion in all these structures. Many place a dominant quality on the South Zenith Summer reference, which thus diminishes the role of the north pole. Thus the seasonal reference is usually dominate in all these cultures.

How did we get from facing North to facing South? Of course the Sun's warmth caught our attention, but it appears not really until late in the Egyptian period.

When we orient off the North pole, it does not matter where you are on the planet, you will always look to the north, and therefore East will be on your right hand and west will be on your left hand. While this is not a problem for the people living in the southern hemisphere, it is a problem for the people living in the northern hemisphere, as they have to turn around and look to the cold north, instead of the warm south. It also messes up the orientation of the northern hemisphere orientated birth charts and all that is deduced from it. Not in the value and meaning of the information, but in the orientation of that information primarily to the switching of the left and right hands, especially when we place emphasis on the left being intuitive and the right to our rational conscious qualities.

This orientation issue was not a problem, while I was developing my diagrams within the one particular reference — northern hemisphere. However once I started to find this same gyroscopic reference showing up in the artwork of past cultures and in Earth monuments, such as cathedrals and especially in the Chartres Labyrinth, then this issue of how to place the astrological referenced information with the Earth orientated structures, became a problem.

In clarifying this difference I am not making one orientation right and the other wrong, I am just clarifying they are different. The significance of the difference will be investigated further, with some reference to Dr Steiner's comments on this matter. (See Appendix 2 - 'The Three Dimensions of Space')

My diagrams

The implications for my diagrams however is relatively significant. My present interest (2010) is to apply the magnetic organisation of the gyroscope to the Earth and to the existing 'earth monuments' we find in things like the Celtic stone circles, the Chartres Labyrinth, the Gothic Chapter Houses, and many of the other Templar structures dotted about Europe. These 'forms of earth power' can be easily created anywhere, with any circle or octagonal form being a manifester of these organisational forces.

To date and throughout this book, my diagrams are drawn with the northern hemisphere reference. This means the next step is to change many of my diagrams, from the orientation of the Zenith to the orientation of North. Thus when you face to the north, the 'old' diagrams need to be flipped horizontally, which means they can not be seen, or you have to have them over your head. The North South pole stays the same. East and West switch over. I began this

process from the 21 March 2010. My earlier diagrams are not wrong, they are just a little difficult to use, when applying them to the Earth sculptures. The information that has been generated from them is still relevant in itself, but we need to be conscious, it is developed from the ecliptic as seen from the northern hemisphere.

The journey I have taken, from the Astrological to the Earth based reference systems is in the opposite direction to that walked by humanity throughout its history. Humanity first came to the northern orientation, with reference to many different stars in the heavens(3000BC) It was much later, (200AD) that 'we' moved to a Sun related orientation. Various cultures, orientated initially off the Pleiades, Sirius, Vega, Canopus, and so on, all stars NOT in the zodiac.

The story of the Egyptian pharaoh Akhenaten indicates the difficulties this change to the Sun created. He was "a Pharaoh of the Eighteenth dynasty of Egypt, who ruled for 17 years and died in 1336 BC or 1334 BC. He is especially noted for abandoning traditional Egyptian polytheism and introducing worship centered on the Aten, which is sometimes described as monotheistic or henotheistic. An early inscription likens him to the sun as compared to stars, and later official language avoids calling the Aten a god, giving the solar deity a status above mere gods." - Wikipedia . Upon his son's death many references to Akhenaten were removed from the hieroglyphic record, and polytheism was re-instituted in Egypt.

What does Humanities Change of Orientation Mean

With reference to several of my earlier articles, (10) I draw your attention to the interesting process of duality we find all around us. Wherever we find two things set against each other, Tropical Signs — Sidereal Constellations, Geocentric — Heliocentric, The Cancer / Leo Zodiac as opposed to the Aries / Pisces zodiac and so on. These 'differences' mirror the duality of Spirit and Matter, or Force and Substance, Cosmic and Earthly, External or Internal organisations, as expressed in the dual, magnetic and seasonal crosses. The conclusion of these explorations is, the more we work with what is astronomically real, the closer we are to the archetype or primal vibration, and thus the closer we are to spirit, while the further we move away from the real astronomical phenomena and move towards something concocted by Human perception, such as the Signs of the zodiac, the closer we move to Matter, or some abstract aspect of matter. In the case of the constellations versus the Signs of the Zodiac, the archetypal information, of the constellations, will describe very unconscious and even collective aspects of the human, e.g. our biological evolution and function, while the more abstract reference, e.g. the signs, in particular, will talk not so much to our body's organisation, but more to the human's psychological organisation, which is a very

abstract thing, in the context of the physical universe.

With the two orientations of this article, we have one focused upon the magnetic northern pole of the Earth, and the other is focused upon the apparent path of the Sun around the Earth, and the small ring of stars behind it. The key feature of this change, is our move to a purely Earth related phenomena from one based upon the Sun and the zodiacal stars. Thus there is a move from our single Star, the Sun, which is the individualising aspect of World Spirit sphere and therefore metaphorically relates to our internalised individualised spirit, to something more physical, yet something very astronomically real.

Initially humanity focused upon the stars in a general manner, which showed their relationship to the Cosmic and collective World Spirit, which changed with the process of humanity focusing upon our Sun as THE deity. This change reaches a peak when we moved from polytheistic religion to monotheistic religion, with the single God, being considered a Earthly representative of the Sun being. While Akhenaten had a go at this, (Judaism has non solar monotheistic tendencies) it was not until Christ's incarnation, and his reference as a solar deity, that Solar monotheism really took hold.

The evolutionary significance of this change, is the reorientation of our focus away from being humans at the mercy of the Gods, (Greek polytheism) to us as individuals, firstly in direct relationship with THE God, (post Luther Christianity), and then to us now as direct personal representatives of THE Solar internalised God. We have moved from the collective to the personal. In correspondence with this development, we can track that we have moved from a empathic 'clairvoyant' consciousness, to the more rational scientific and defining consciousness. Thus we have moved away from the Earth within the many starred Cosmic dome, to the Sun as its own central reference.

My chapters on the 'Birth Chart' indicate just how far we have traveled, in the process of identifying our personal consciousness' karmic life, here on Earth.

Stepping 'forward' to an astronomical Earth orientation, based on the Earth's magnetic pole, can be seen as either a further internalisation of the Spirit, thus 'individualising the Earth' , and a symbol of a further internalisation of the Sun principle, and thus full spiritual responsibility for oneself or simply it is a step to more practical and physical applications, which become useful for doing stuff on Earth, like dealing with chemistry and agriculture and energy organisation on Earth.

My interest in this is two fold. Firstly, we have the energetic reality of the Earths electro magnetic field. This is a free source of energy, that is always present,

forever being regenerated by the mere process of the Earth moving through space. Thus this is an energy field at our disposal, 24 hours a day anywhere on the planet. Why not make use of it, as a energetic recharging source for the unconscious processes still active within our bodies, and especially for the beings still embedded fully in this matrix, the soil, plants and animals?

Secondly, because we have many Earth orientated structures, dotted about the planet created by past civilisations, who knew of this 'free' power. These ancient places are placed on points of intensified earth energy, which makes them especially worth visiting. The biggest problem though is we do not have much conscious information about what these places are, and what they can do.

The archetypal organisational reference, I have developed along the Astrological Biodynamic journey, is directly relatable to the Earth magnetic field, and therefore it provides an interpretative image of the organisation existing within these Earth structures. Thus we can have an image of the function of the complex of energies present, anytime we draw a circle or an octagon.



